

Innovations Customized

MRS[®]
MODULAR
RACK SYSTEMS PVT LTD

**HIGH DENSITY
CABLE MANAGERS**



High Density Vertical Cable Managers



CERTIFIED

MRS high-density vertical cable managers are specially designed to meet the challenges of high-density cable management due to increasing on of patch panel per rack and also the introduction of angular jack panel.

Cable manager frame manufactured out of steel sheet punched, formed, welded and powder coated and doors made of steel sheet / aluminum sheet punched formed and powder coated with highest quality standards to ensure the highest quality product.

Standard configuration will be 6", 8", 12" & 15" with a unique double-hinged door on the front & back associated with removable / reusable fingers made of polycarbonate material. Available in front or front back variants.

High Density Vertical Cable Managers

PRODUCT DETAILS

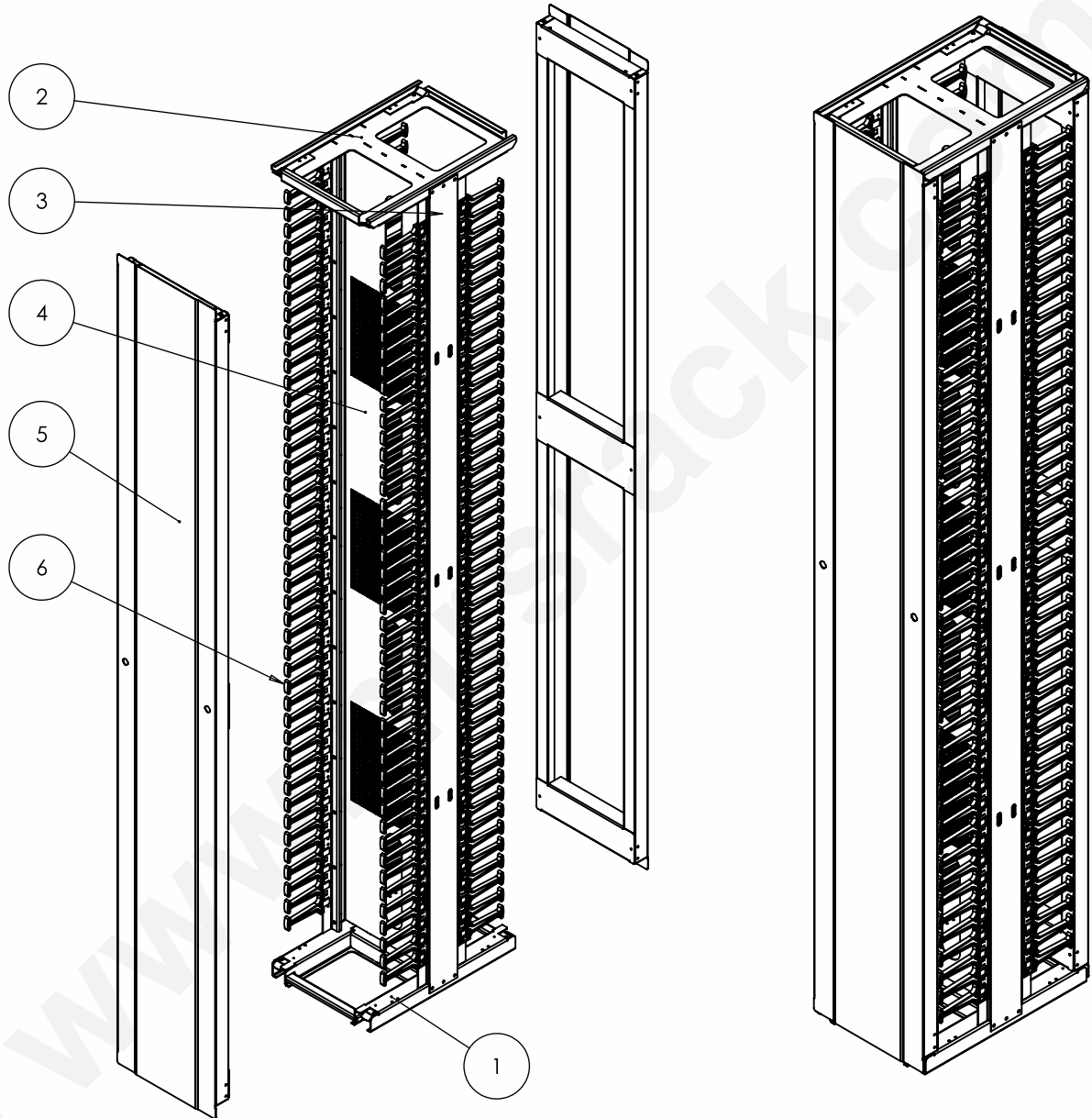

- 1 HDVCM-Bottom
- 2 HDVCM-Top
- 3 HDVCM-Side
- 4 Center Plate
- 5 Door Assembly
- 6 Finger Loop

Product Features

- ◆ Finger can be removed very easily to suit site requirements.
- ◆ Unique double hinge design door at front and back to open door from left to right or right to left for easy cable management.
- ◆ The vertical cable manager free standing on floor and bolted to open rack for better alignment and aesthetic looks.
- ◆ Composite construction basic frame-steel powder coated and fingers made of poly carbonate for high strength to carry large quantity cables.
- ◆ Cable spools and slots in centre supported member for large quantity cable management.
- ◆ Polycarbonate fingers assure no cable damage.

Product Codes and Dimensions

PART CODE	Total Height in MM (H)	Usable Height in U (H)	Total Width in Inches (W)	Total Depth in MM (W)	Description
MRS-HDVCM-FB-06	2140	45U	06	458	Front & Back
MRS-HDVCM-FB-08	2140	45U	08	458	Front & Back
MRS-HDVCM-FB-12	2140	45U	12	458	Front & Back
MRS-HDVCM-FB-15	2140	45U	15	458	Front & Back
MRS-HDVCM-FO-06	2140	45U	06	245	Front Only
MRS-HDVCM-FO-08	2140	45U	08	245	Front Only
MRS-HDVCM-FO-12	2140	45U	12	245	Front Only
MRS-HDVCM-FO-15	2140	45U	15	245	Front Only

1U = 44.45 mm / 1.75 Inch

Note:

1. Customized models can be manufactured on request.
2. Different color options with powder coating
3. All dimensions are in mm.



MODULAR RACK SYSTEMS PVT. LTD.

No. 189 & 190, Nadikerappa Industrial Estate, Hegganahalli, Vishwanedam Post, Bangalore-560 091 INDIA • Tel: +91 80 28365042 • Fax: +91 80 28367881
Mobile: +91 9108220086 • Email: admin@mrsrack.com



Innovations Customized

MRS[®]
MODULAR
RACK SYSTEMS PVT LTD

**HIGH DENSITY
CABLE MANAGERS**





CERTIFIED

MRS high-density vertical cable managers are specially designed to meet the challenges of high-density cable management due to increasing on of patch panel per rack and also the introduction of angular jack panel.

Cable manager frame manufactured out of steel sheet punched, formed, welded and powder coated and doors made of steel sheet / aluminum sheet punched formed and powder coated with highest quality standards to ensure the highest quality product.

Standard configuration will be 6", 8", 12" & 15" with a unique double-hinged door on the front & back associated with removable / reusable fingers made of polycarbonate material. Available in front or front back variants.

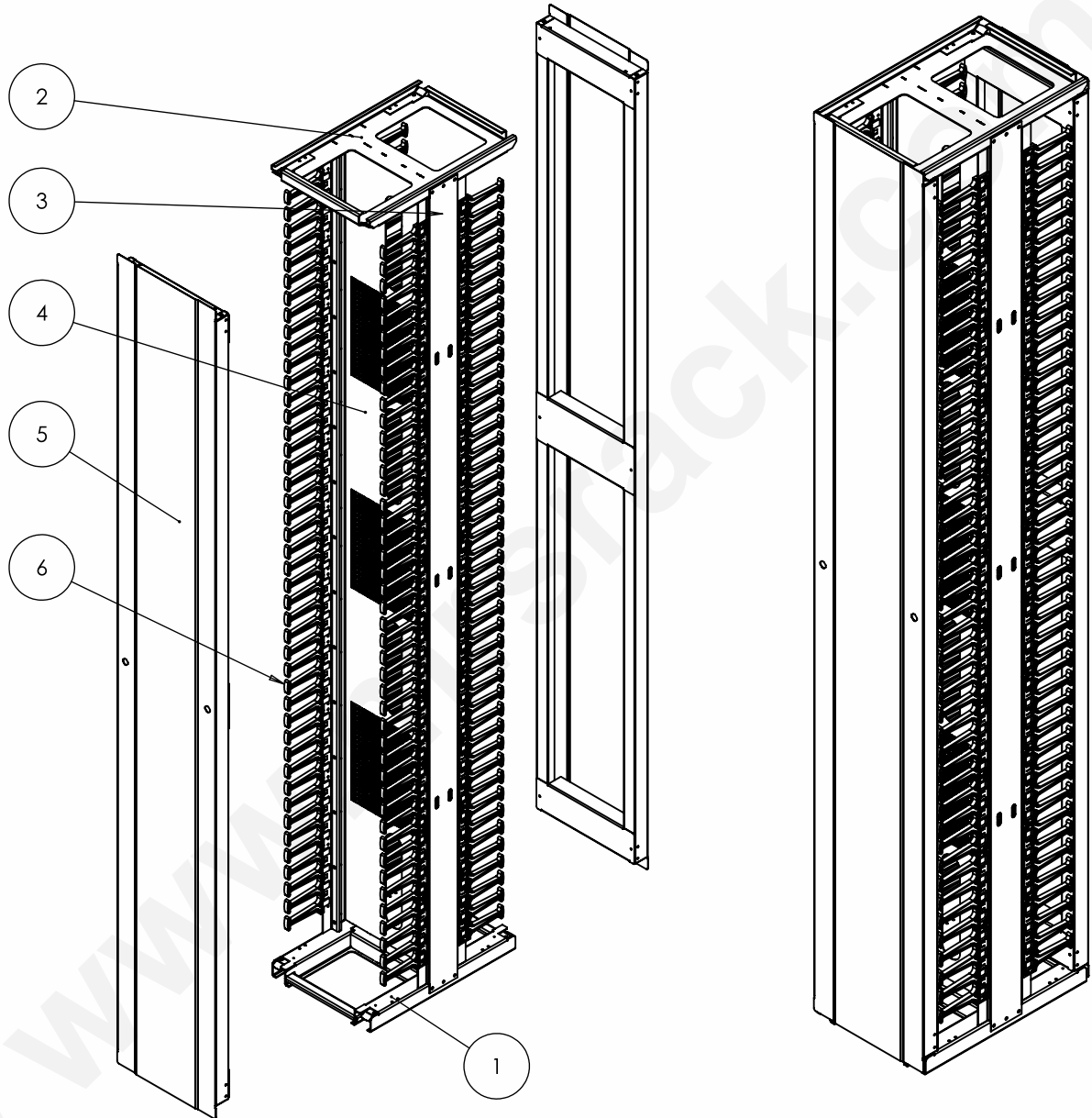

- 1 06" HDVCM-Bottom
- 2 06" HDVCM-Top
- 3 06" HDVCM-Side
- 4 Center Plate
- 5 Door Assembly
- 6 Finger Loop

Product Features

- ◆ Finger can be removed very easily to suit site requirements.
- ◆ Unique double hinge design door at front and back to open door from left to right or right to left for easy cable management.
- ◆ The vertical cable manager free standing on floor and bolted to open rack for better alignment and aesthetic looks.
- ◆ Composite construction basic frame-steel powder coated and fingers made of poly carbonate for high strength to carry large quantity cables.
- ◆ Cable spools and slots in centre supported member for large quantity cable management.
- ◆ Polycarbonate fingers assure no cable damage.

▶ Product Codes and Dimensions

PART CODE	Total Height in MM (H)	Usable Height in U (H)	Total Width in Inches (W)	Total Depth in MM (W)	Description
MRS-HDVCM-FB-06	2140	45U	06	458	Front & Back

1U = 44.45 mm / 1.75 Inch

Note:

1. Customized models can be manufactured on request.
2. Different color options with powder coating
3. All dimensions are in mm.

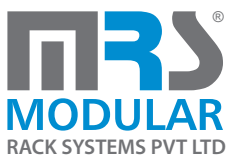

MODULAR RACK SYSTEMS PVT. LTD.

No. 189 & 190, Nadikerappa Industrial Estate, Hegganahalli, Vishwanedam Post, Bangalore-560 091 INDIA • Tel: +91 80 28365042 • Fax: +91 80 28367881
Mobile: +91 9108220086 • Email: admin@mrsrack.com



Innovations Customized

MRS[®]
MODULAR
RACK SYSTEMS PVT LTD

**HIGH DENSITY
CABLE MANAGERS**





CERTIFIED

MRS high-density vertical cable managers are specially designed to meet the challenges of high-density cable management due to increasing on of patch panel per rack and also the introduction of angular jack panel.

Cable manager frame manufactured out of steel sheet punched, formed, welded and powder coated and doors made of steel sheet / aluminum sheet punched formed and powder coated with highest quality standards to ensure the highest quality product.

Standard configuration will be 6", 8", 12" & 15" with a unique double-hinged door on the front & back associated with removable / reusable fingers made of polycarbonate material. Available in front or front back variants.

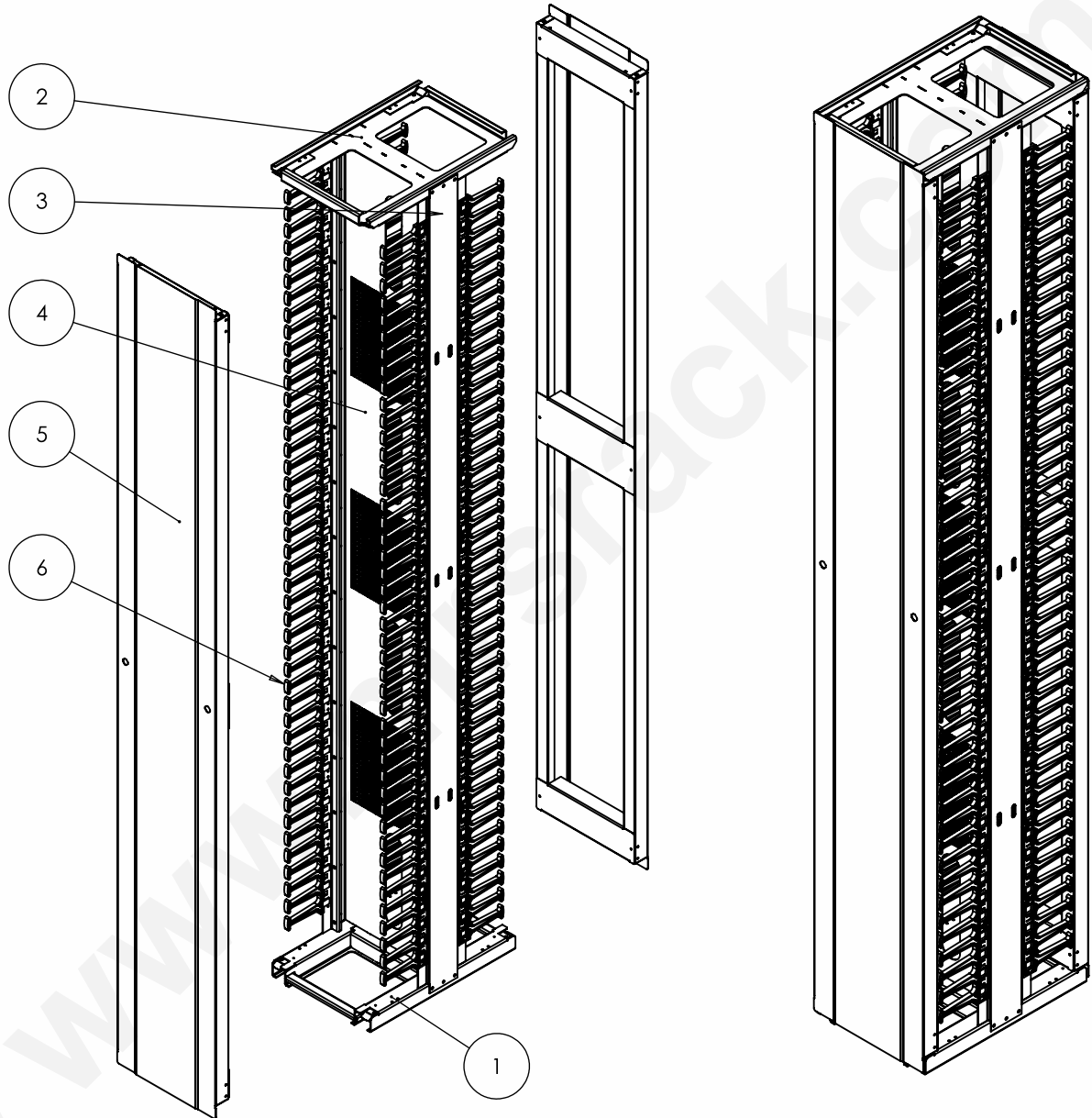

- 1 08" HDVCM-Bottom
- 2 08" HDVCM-Top
- 3 08" HDVCM-Side
- 4 Center Plate
- 5 Door Assembly
- 6 Finger Loop

Product Features

- ◆ Finger can be removed very easily to suit site requirements.
- ◆ Unique double hinge design door at front and back to open door from left to right or right to left for easy cable management.
- ◆ The vertical cable manager free standing on floor and bolted to open rack for better alignment and aesthetic looks.
- ◆ Composite construction basic frame-steel powder coated and fingers made of poly carbonate for high strength to carry large quantity cables.
- ◆ Cable spools and slots in centre supported member for large quantity cable management.
- ◆ Polycarbonate fingers assure no cable damage.

▶ Product Codes and Dimensions

PART CODE	Total Height in MM (H)	Usable Height in U (H)	Total Width in Inches (W)	Total Depth in MM (W)	Description
MRS-HDVCM-FB-08	2140	45U	08	458	Front & Back

1U = 44.45 mm / 1.75 Inch

Note:

1. Customized models can be manufactured on request.
2. Different color options with powder coating
3. All dimensions are in mm.

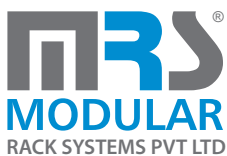

MODULAR RACK SYSTEMS PVT. LTD.

No. 189 & 190, Nadikerappa Industrial Estate, Hegganahalli, Vishwanedam Post, Bangalore-560 091 INDIA • Tel: +91 80 28365042 • Fax: +91 80 28367881
Mobile: +91 9108220086 • Email: admin@mrsrack.com



Innovations Customized

MRS[®]
MODULAR
RACK SYSTEMS PVT LTD

**HIGH DENSITY
CABLE MANAGERS**

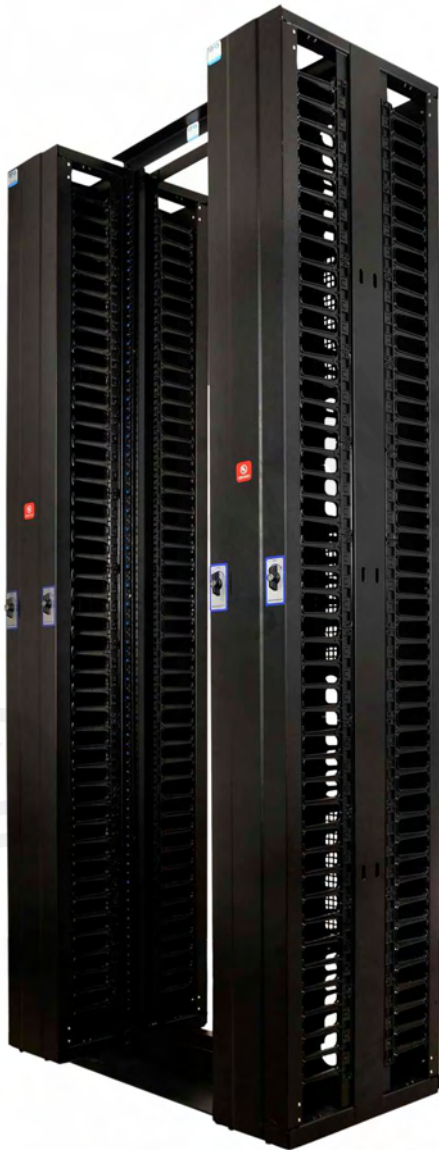



CERTIFIED

MRS high-density vertical cable managers are specially designed to meet the challenges of high-density cable management due to increasing on of patch panel per rack and also the introduction of angular jack panel.

Cable manager frame manufactured out of steel sheet punched, formed, welded and powder coated and doors made of steel sheet / aluminum sheet punched formed and powder coated with highest quality standards to ensure the highest quality product.

Standard configuration will be 6", 8", 12" & 15" with a unique double-hinged door on the front & back associated with removable / reusable fingers made of polycarbonate material. Available in front or front back variants.

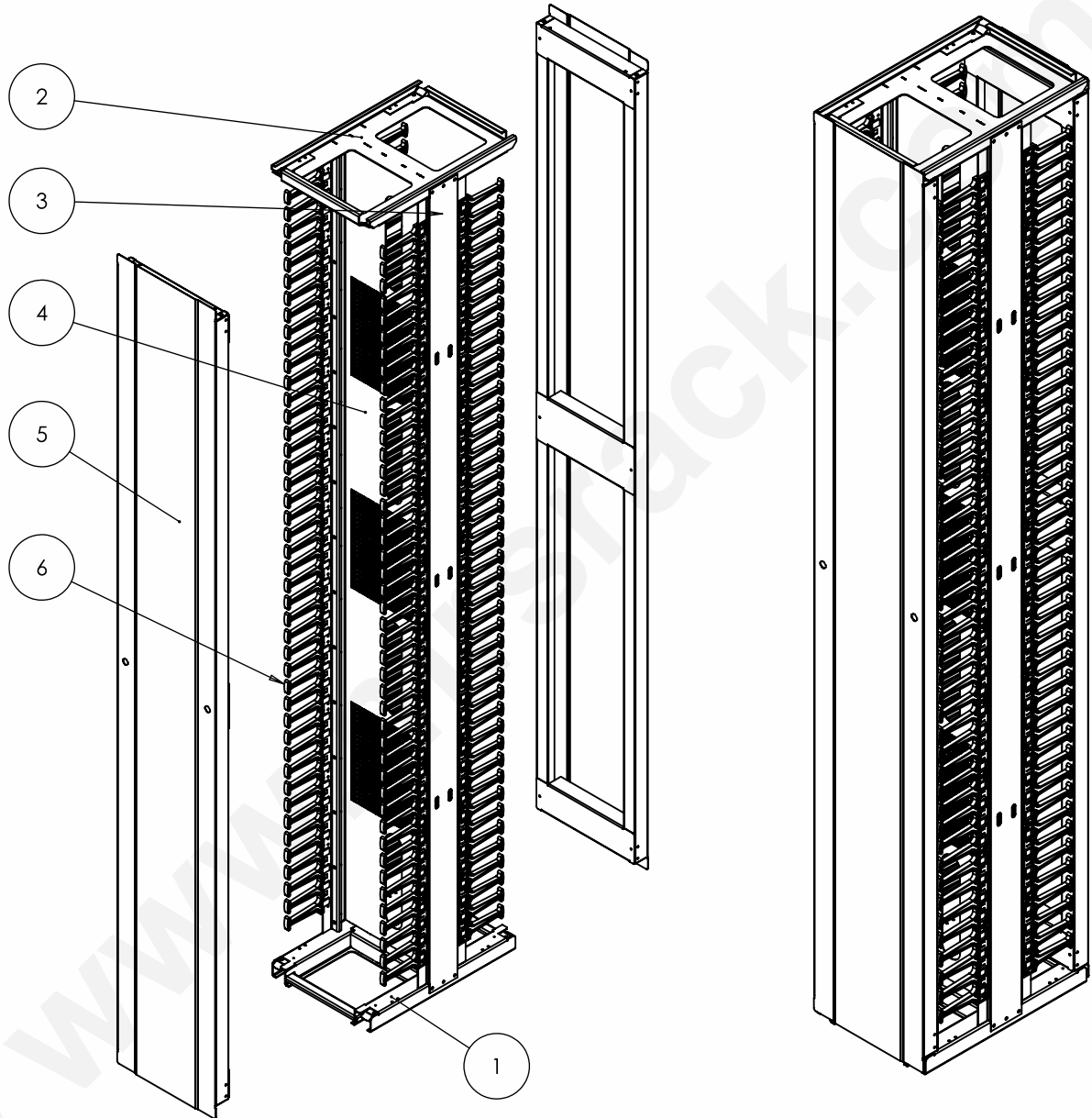

- 1 12" HDVCM-Bottom
- 2 12" HDVCM-Top
- 3 12" HDVCM-Side
- 4 Center Plate
- 5 Door Assembly
- 6 Finger Loop

Product Features

- ◆ Finger can be removed very easily to suit site requirements.
- ◆ Unique double hinge design door at front and back to open door from left to right or right to left for easy cable management.
- ◆ The vertical cable manager free standing on floor and bolted to open rack for better alignment and aesthetic looks.
- ◆ Composite construction basic frame-steel powder coated and fingers made of poly carbonate for high strength to carry large quantity cables.
- ◆ Cable spools and slots in centre supported member for large quantity cable management.
- ◆ Polycarbonate fingers assure no cable damage.

▶ Product Codes and Dimensions

PART CODE	Total Height in MM (H)	Usable Height in U (H)	Total Width in Inches (W)	Total Depth in MM (W)	Description
MRS-HDVCM-FB-12	2140	45U	12	458	Front & Back

1U = 44.45 mm / 1.75 Inch

Note:

1. Customized models can be manufactured on request.
2. Different color options with powder coating
3. All dimensions are in mm.



MODULAR RACK SYSTEMS PVT. LTD.

No. 189 & 190, Nadikerappa Industrial Estate, Hegganahalli, Vishwanedam Post, Bangalore-560 091 INDIA • Tel: +91 80 28365042 • Fax: +91 80 28367881
Mobile: +919108220086 • Email: admin@mrsrack.com



Innovations Customized

MRS[®]
MODULAR
RACK SYSTEMS PVT LTD

**HIGH DENSITY
CABLE MANAGERS**





CERTIFIED

MRS high-density vertical cable managers are specially designed to meet the challenges of high-density cable management due to increasing on of patch panel per rack and also the introduction of angular jack panel.

Cable manager frame manufactured out of steel sheet punched, formed, welded and powder coated and doors made of steel sheet / aluminum sheet punched formed and powder coated with highest quality standards to ensure the highest quality product.

Standard configuration will be 6", 8", 12" & 15" with a unique double-hinged door on the front & back associated with removable / reusable fingers made of polycarbonate material. Available in front or front back variants.

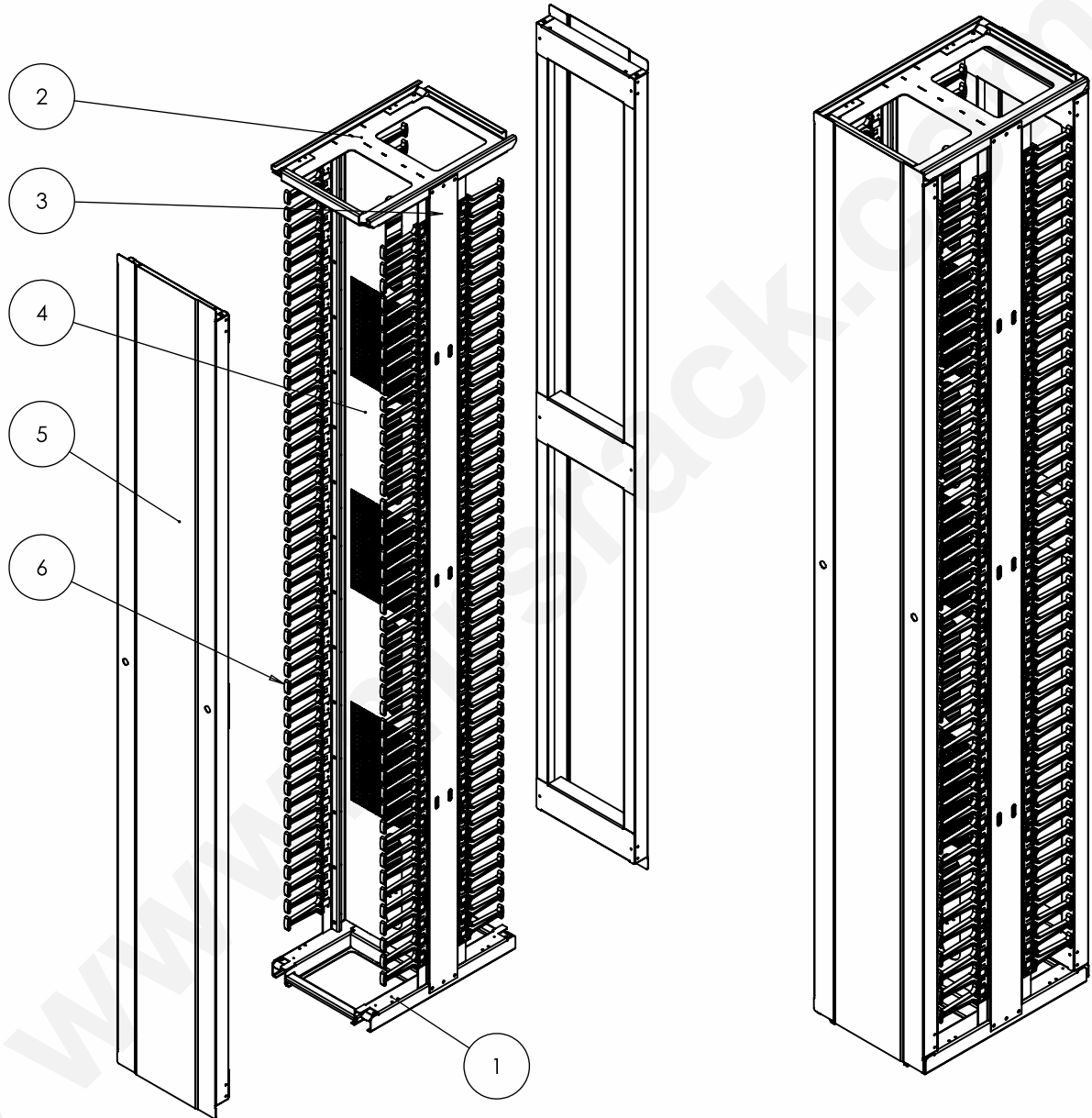

- 1 15" HDVCM-Bottom
- 2 15" HDVCM-Top
- 3 15" HDVCM-Side
- 4 Center Plate
- 5 Door Assembly
- 6 Finger Loop

Product Features

- ◆ Finger can be removed very easily to suit site requirements.
- ◆ Unique double hinge design door at front and back to open door from left to right or right to left for easy cable management.
- ◆ The vertical cable manager free standing on floor and bolted to open rack for better alignment and aesthetic looks.
- ◆ Composite construction basic frame-steel powder coated and fingers made of poly carbonate for high strength to carry large quantity cables.
- ◆ Cable spools and slots in centre supported member for large quantity cable management.
- ◆ Polycarbonate fingers assure no cable damage.

▶ Product Codes and Dimensions

PART CODE	Total Height in MM (H)	Usable Height in U (H)	Total Width in Inches (W)	Total Depth in MM (W)	Description
MRS-HDVCM-FB-15	2140	45U	15	458	Front & Back

1U = 44.45 mm / 1.75 Inch

Note:

1. Customized models can be manufactured on request.
2. Different color options with powder coating
3. All dimensions are in mm.

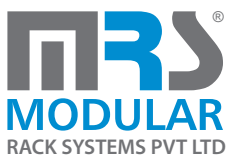

MODULAR RACK SYSTEMS PVT. LTD.

No. 189 & 190, Nadikerappa Industrial Estate, Hegganahalli, Vishwanedam Post, Bangalore-560 091 INDIA • Tel: +91 80 28365042 • Fax: +91 80 28367881
Mobile: +91 9108220086 • Email: admin@mrsrack.com



Innovations Customized

MRS[®]
MODULAR
RACK SYSTEMS PVT LTD

**HIGH DENSITY
CABLE MANAGERS**

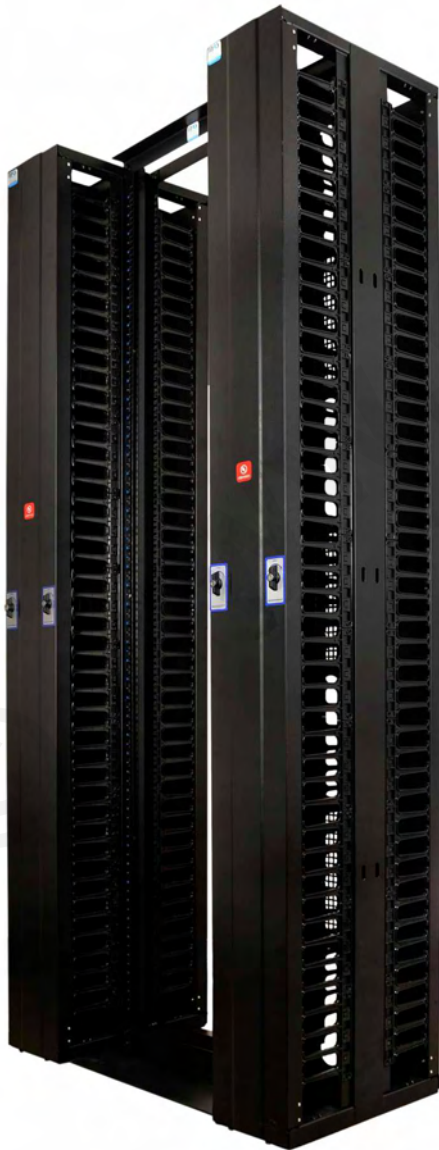



CERTIFIED

MRS high-density vertical cable managers are specially designed to meet the challenges of high-density cable management due to increasing on of patch panel per rack and also the introduction of angular jack panel.

Cable manager frame manufactured out of steel sheet punched, formed, welded and powder coated and doors made of steel sheet / aluminum sheet punched formed and powder coated with highest quality standards to ensure the highest quality product.

Standard configuration will be 6", 8", 12" & 15" with a unique double-hinged door on the front & back associated with removable / reusable fingers made of polycarbonate material. Available in front or front back variants.

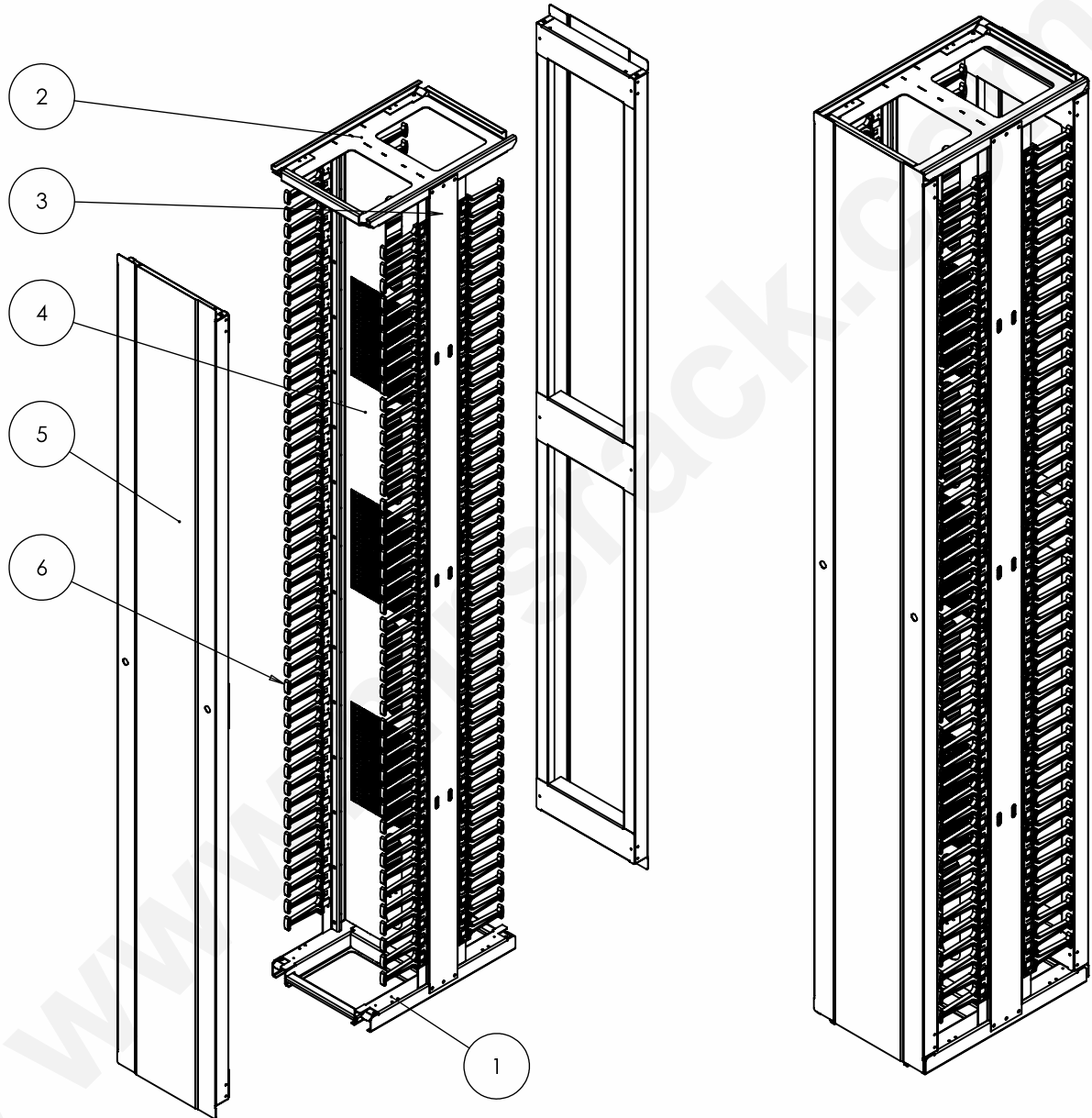

- 1 06" HDVCM-Bottom
- 2 06" HDVCM-Top
- 3 06" HDVCM-Side
- 4 Center Plate
- 5 Door Assembly
- 6 Finger Loop

Product Features

- ◆ Finger can be removed very easily to suit site requirements.
- ◆ Unique double hinge design door at front and back to open door from left to right or right to left for easy cable management.
- ◆ The vertical cable manager free standing on floor and bolted to open rack for better alignment and aesthetic looks.
- ◆ Composite construction basic frame-steel powder coated and fingers made of poly carbonate for high strength to carry large quantity cables.
- ◆ Cable spools and slots in centre supported member for large quantity cable management.
- ◆ Polycarbonate fingers assure no cable damage.

▶ Product Codes and Dimensions

PART CODE	Total Height in MM (H)	Usable Height in U (H)	Total Width in Inches (W)	Total Depth in MM (W)	Description
MRS-HDVCM-FO-06	2140	45U	06	245	Front Only

1U = 44.45 mm / 1.75 Inch

Note:

1. Customized models can be manufactured on request.
2. Different color options with powder coating
3. All dimensions are in mm.



MODULAR RACK SYSTEMS PVT. LTD.

No. 189 & 190, Nadikerappa Industrial Estate, Hegganahalli, Vishwanedam Post, Bangalore-560 091 INDIA • Tel: +91 80 28365042 • Fax: +91 80 28367881
Mobile: +91 9108220086 • Email: admin@mrsrack.com



Innovations Customized

MRS[®]
MODULAR
RACK SYSTEMS PVT LTD

**HIGH DENSITY
CABLE MANAGERS**





CERTIFIED

MRS high-density vertical cable managers are specially designed to meet the challenges of high-density cable management due to increasing on of patch panel per rack and also the introduction of angular jack panel.

Cable manager frame manufactured out of steel sheet punched, formed, welded and powder coated and doors made of steel sheet / aluminum sheet punched formed and powder coated with highest quality standards to ensure the highest quality product.

Standard configuration will be 6", 8", 12" & 15" with a unique double-hinged door on the front & back associated with removable / reusable fingers made of polycarbonate material. Available in front or front back variants.

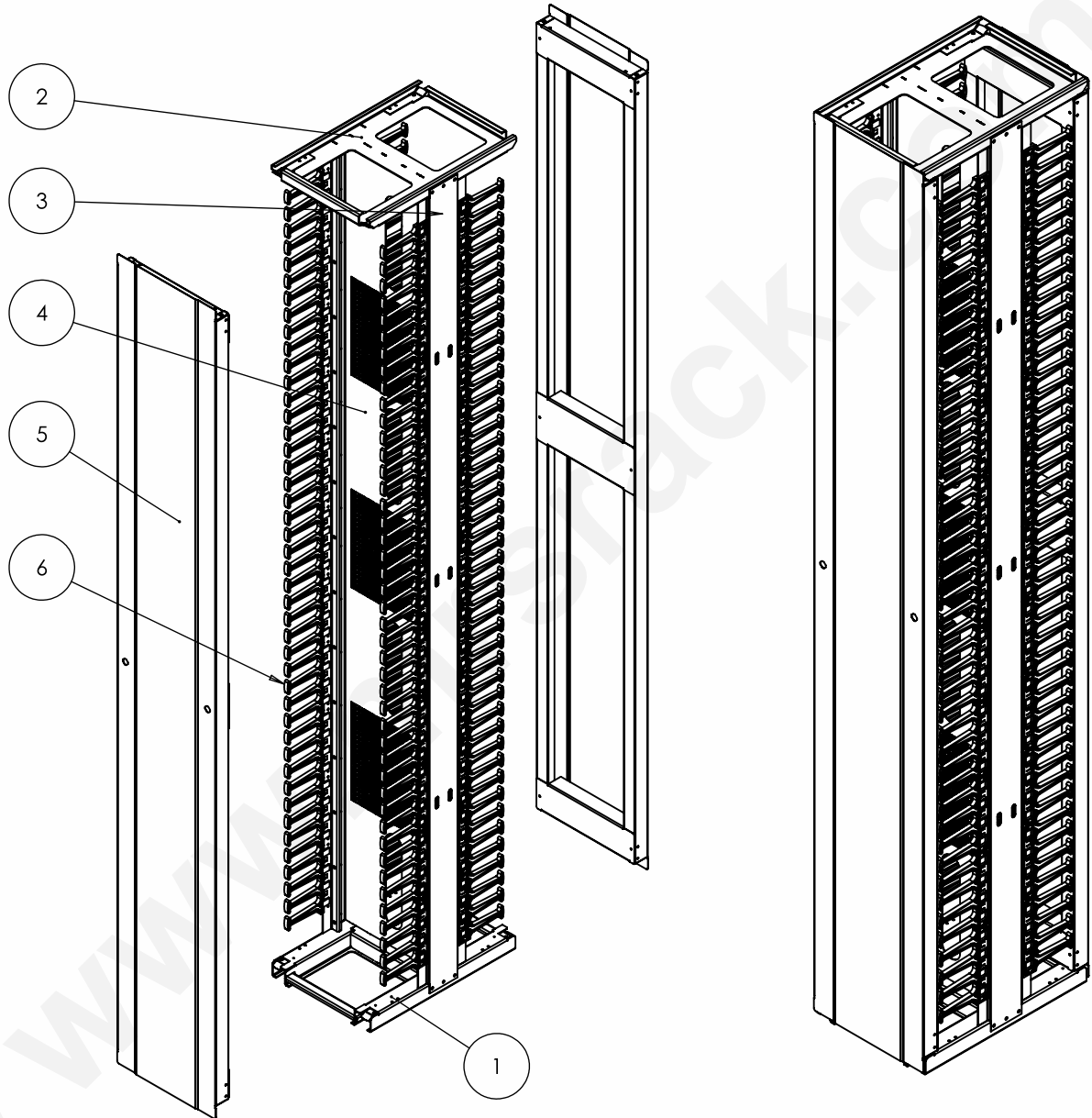

- 1 08" HDVCM-Bottom
- 2 08" HDVCM-Top
- 3 08" HDVCM-Side
- 4 Center Plate
- 5 Door Assembly
- 6 Finger Loop

Product Features

- ◆ Finger can be removed very easily to suit site requirements.
- ◆ Unique double hinge design door at front and back to open door from left to right or right to left for easy cable management.
- ◆ The vertical cable manager free standing on floor and bolted to open rack for better alignment and aesthetic looks.
- ◆ Composite construction basic frame-steel powder coated and fingers made of poly carbonate for high strength to carry large quantity cables.
- ◆ Cable spools and slots in centre supported member for large quantity cable management.
- ◆ Polycarbonate fingers assure no cable damage.

▶ Product Codes and Dimensions

PART CODE	Total Height in MM (H)	Usable Height in U (H)	Total Width in Inches (W)	Total Depth in MM (W)	Description
MRS-HDVCM-FO-08	2140	45U	08	245	Front Only

1U = 44.45 mm / 1.75 Inch

Note:

1. Customized models can be manufactured on request.
2. Different color options with powder coating
3. All dimensions are in mm.



MODULAR RACK SYSTEMS PVT. LTD.

No. 189 & 190, Nadikerappa Industrial Estate, Hegganahalli, Vishwanedam Post, Bangalore-560 091 INDIA • Tel: +91 80 28365042 • Fax: +91 80 28367881
Mobile: +91 9108220086 • Email: admin@mrsrack.com



Innovations Customized

MRS[®]
MODULAR
RACK SYSTEMS PVT LTD

**HIGH DENSITY
CABLE MANAGERS**





CERTIFIED

MRS high-density vertical cable managers are specially designed to meet the challenges of high-density cable management due to increasing on of patch panel per rack and also the introduction of angular jack panel.

Cable manager frame manufactured out of steel sheet punched, formed, welded and powder coated and doors made of steel sheet / aluminum sheet punched formed and powder coated with highest quality standards to ensure the highest quality product.

Standard configuration will be 6", 8", 12" & 15" with a unique double-hinged door on the front & back associated with removable / reusable fingers made of polycarbonate material. Available in front or front back variants.

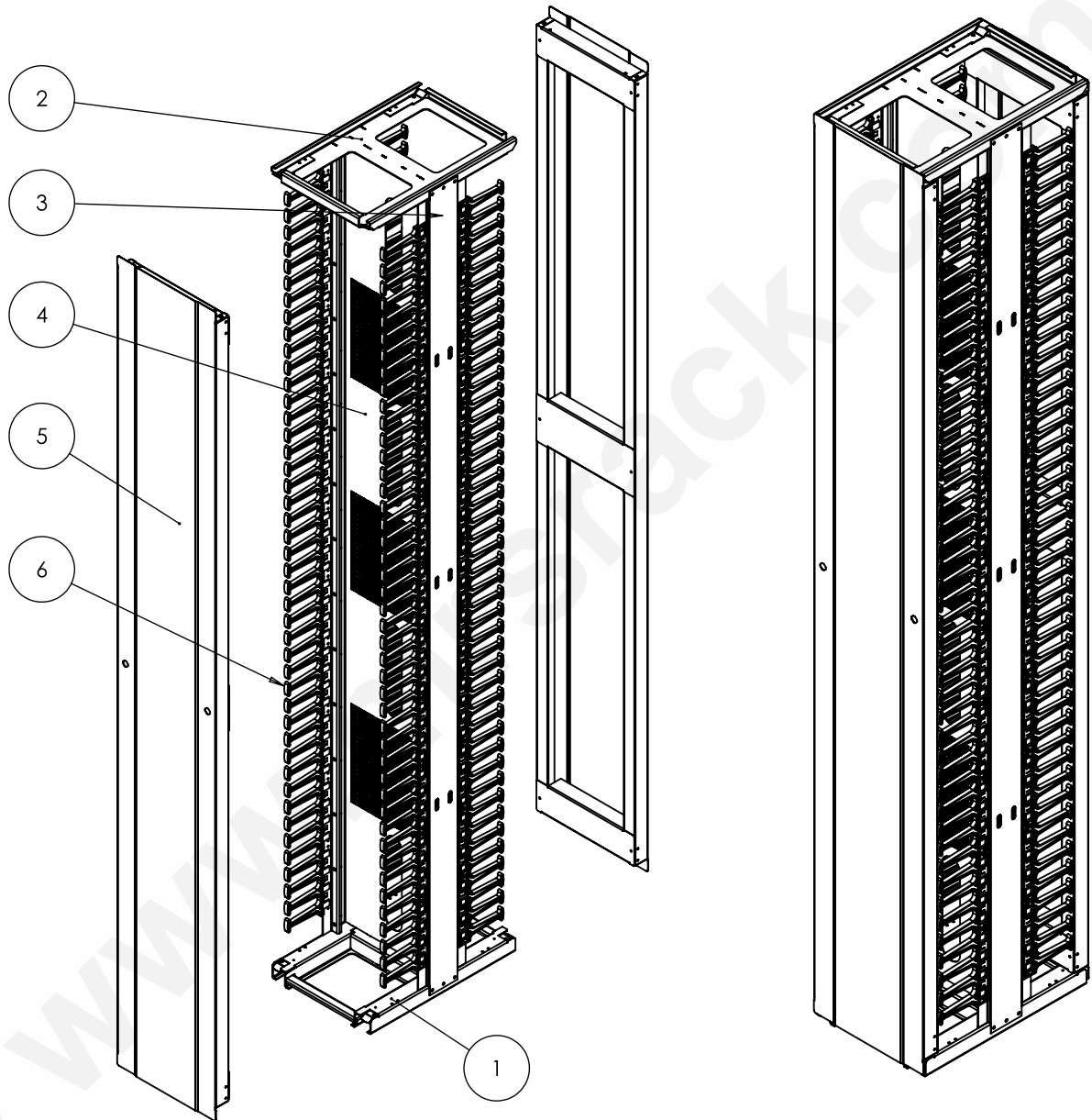

- 1 12" HDVCM-Bottom
- 2 12" HDVCM-Top
- 3 12" HDVCM-Side
- 4 Center Plate
- 5 Door Assembly
- 6 Finger Loop

Product Features

- ◆ Finger can be removed very easily to suit site requirements.
- ◆ Unique double hinge design door at front and back to open door from left to right or right to left for easy cable management.
- ◆ The vertical cable manager free standing on floor and bolted to open rack for better alignment and aesthetic looks.
- ◆ Composite construction basic frame-steel powder coated and fingers made of poly carbonate for high strength to carry large quantity cables.
- ◆ Cable spools and slots in centre supported member for large quantity cable management.
- ◆ Polycarbonate fingers assure no cable damage.

▶ Product Codes and Dimensions

PART CODE	Total Height in MM (H)	Usable Height in U (H)	Total Width in Inches (W)	Total Depth in MM (W)	Description
MRS-HDVCM-FO-12	2140	45U	12	245	Front Only

1U = 44.45 mm / 1.75 Inch

Note:

1. Customized models can be manufactured on request.
2. Different color options with powder coating
3. All dimensions are in mm.



MODULAR RACK SYSTEMS PVT. LTD.

No. 189 & 190, Nadikerappa Industrial Estate, Hegganahalli, Vishwanedam Post, Bangalore-560 091 INDIA • Tel: +91 80 28365042 • Fax: +91 80 28367881
Mobile: +91 9108220086 • Email: admin@mrsrack.com



Innovations Customized

MRS[®]
MODULAR
RACK SYSTEMS PVT LTD

**HIGH DENSITY
CABLE MANAGERS**





CERTIFIED

MRS high-density vertical cable managers are specially designed to meet the challenges of high-density cable management due to increasing on of patch panel per rack and also the introduction of angular jack panel.

Cable manager frame manufactured out of steel sheet punched, formed, welded and powder coated and doors made of steel sheet / aluminum sheet punched formed and powder coated with highest quality standards to ensure the highest quality product.

Standard configuration will be 6", 8", 12" & 15" with a unique double-hinged door on the front & back associated with removable / reusable fingers made of polycarbonate material. Available in front or front back variants.

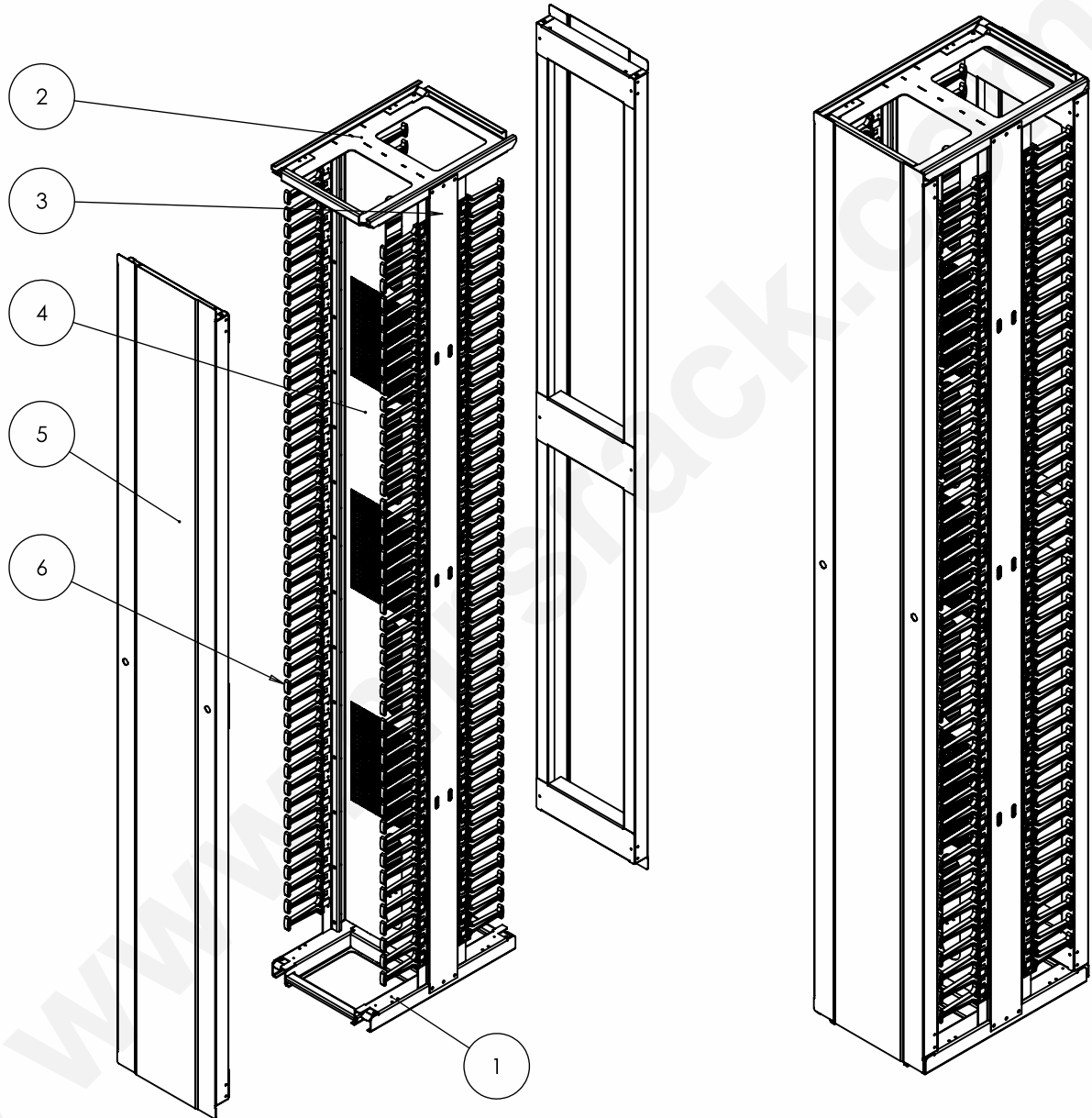

- 1 15" HDVCM-Bottom
- 2 15" HDVCM-Top
- 3 15" HDVCM-Side
- 4 Center Plate
- 5 Door Assembly
- 6 Finger Loop

Product Features

- ◆ Finger can be removed very easily to suit site requirements.
- ◆ Unique double hinge design door at front and back to open door from left to right or right to left for easy cable management.
- ◆ The vertical cable manager free standing on floor and bolted to open rack for better alignment and aesthetic looks.
- ◆ Composite construction basic frame-steel powder coated and fingers made of poly carbonate for high strength to carry large quantity cables.
- ◆ Cable spools and slots in centre supported member for large quantity cable management.
- ◆ Polycarbonate fingers assure no cable damage.

▶ Product Codes and Dimensions

PART CODE	Total Height in MM (H)	Usable Height in U (H)	Total Width in Inches (W)	Total Depth in MM (W)	Description
MRS-HDVCM-FO-15	2140	45U	15	245	Front Only

1U = 44.45 mm / 1.75 Inch

Note:

1. Customized models can be manufactured on request.
2. Different color options with powder coating
3. All dimensions are in mm.

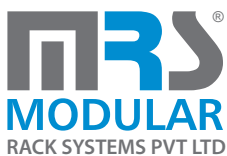

MODULAR RACK SYSTEMS PVT. LTD.

No. 189 & 190, Nadikerappa Industrial Estate, Hegganahalli, Vishwanedam Post, Bangalore-560 091 INDIA • Tel: +91 80 28365042 • Fax: +91 80 28367881
Mobile: +91 9108220086 • Email: admin@mrsrack.com

